

GENERAL NOTES:  
 BREAK EXTERNAL AND INTERNAL EDGES 0.1x45°  
 AR COATING: In & OUT, VIS RANGE  
 HART PROTECTIVE COATING  
 WATER PROOFING COATING

NOTE 1:  
 BOTH SIDES TO BE POLISHED  
 SURFACE QUALITY: 80-50 s-d

NOTE 2:  
 FINISH ON THIS SIDE IS NOT CRITICAL - STANDARD FINISH ACCEPTABLE

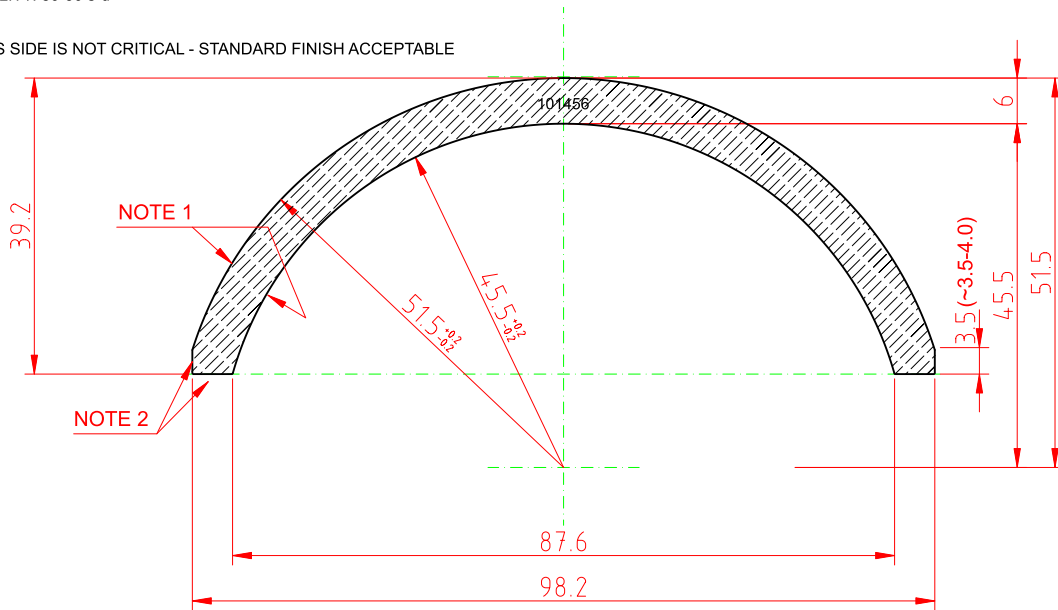

MASSSTAB: 1:1	WERKSTOFF: BK7	NAME: JS	DATUM: 20141216	ZEICHNUNGS NR.: 101456
------------------	-------------------	-------------	--------------------	---------------------------

PROJEKT: J1014-DOM98.3
---------------------------

VERTRAULICH: ALLE RECHTEVORBEHALTE Weitergabe oder Vervielfältigung ohne vorherige schriftliche Zustimmung der Firma CMS-Ing.Dr.Schredre GmbH ist Verboten.  
 The drawing is property to CMS-Ing. Dr. Schredre GmbH and must not be copied or disclosed to a third party without the written consent of CMS-Ing. Dr. Schredre GmbH.  
 CMS - ING.DR.SCHREDER GmbH, LOFERERSTRASSE 32, A-6322 KIRCHBICHL, Tel.: 0043(0)533277056, Email: info@schredre-cms.com