

GENERAL NOTES:  
BREAK EXTERNAL AND INTERNAL EDGES 0.1x45°

NOTE 1:  
BOTH SIDES TO BE POLISHED  
SURFACE QUALITY: 60-40 s-d  
SURFACE ERROR: 1 WAVE

NOTE 2:  
FINISH ON THIS SIDE IS NOT CRITICAL - STANDARD FINISH ACCEPTABLE

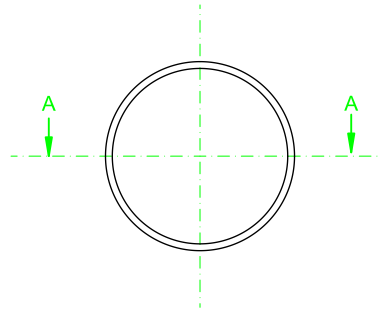
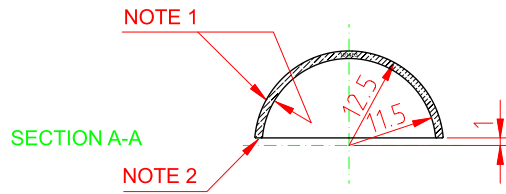

MASSTAB: 1:1	WERKSTOFF: N-BK7 GLASS, CLEAR	NAME: JS	DATUM: 20091214 rev: 20151118	ZEICHNUNGS NR.: 101463	
-----------------	----------------------------------	-------------	-------------------------------------	---------------------------	--

PROJEKT:  <b>J1014-DOM25</b>
------------------------------------

VERTRAULICH: ALLE RECHTEVORBEHALTE Weitergabe oder Vervielfältigung ohne vorherige schriftliche Zustimmung der Firma CMS-Ing.Dr.Schreder GmbH ist Verboten.  
The drawing is property to CMS-Ing. Dr. Schreder GmbH and must not be copied or disclosed to a third party without the written consent of CMS-Ing. Dr. Schreder GmbH.  
CMS - ING.DR.SCHREDER GmbH, LOFERERSTRASSE 32, A-6322 KIRCHBICHL, Tel.: 0043(0)5332/77056, Email: info@schreder-cms.com